

UW-2(a)], except as permitted by ULW-76 for vent holes in layered construction. When telltale holes are provided, they shall have a diameter of $\frac{1}{16}$ in. to $\frac{3}{16}$ in. (1.5 mm to 5 mm) and have a depth not less than 80% of the thickness required for a seamless shell of like dimensions. These holes shall be provided in the opposite surface to that where deterioration is expected. [For telltale holes in clad or lined vessels, see UCL-25(b).]

(f) *Openings for Drain.* Vessels subject to corrosion shall be supplied with a suitable drain opening at the lowest point practicable in the vessel; or a pipe may be used extending inward from any other location to within $\frac{1}{4}$ in. (6 mm) of the lowest point.

UG-26 LININGS

Corrosion resistant or abrasion resistant linings, whether or not attached to the wall of a vessel, shall not be considered as contributing to the strength of the wall except as permitted in Part UCL (see Appendix F).

UG-27 THICKNESS OF SHELLS UNDER INTERNAL PRESSURE

(a) The minimum required thickness of shells under internal pressure shall not be less than that computed by the following formulas,¹⁴ except as permitted by Appendix 32. In addition, provision shall be made for any of the loadings listed in UG-22, when such loadings are expected. The provided thickness of the shells shall also meet the requirements of UG-16, except as permitted in Appendix 32.

(b) The symbols defined below are used in the formulas of this paragraph.

E = joint efficiency for, or the efficiency of, appropriate joint in cylindrical or spherical shells, or the efficiency of ligaments between openings, whichever is less.

For welded vessels, use the efficiency specified in UW-12.

For ligaments between openings, use the efficiency calculated by the rules given in UG-53.

P = internal design pressure (see UG-21)

R = inside radius of the shell course under consideration,¹⁵

S = maximum allowable stress value (see UG-23 and the stress limitations specified in UG-24)

t = minimum required thickness of shell

¹⁴ Formulas in terms of the outside radius and for thicknesses and pressures beyond the limits fixed in this paragraph are given in I-1 to I-3.

¹⁵ For pipe, the inside radius R is determined by the nominal outside radius minus the nominal wall thickness.

(c) *Cylindrical Shells.* The minimum thickness or maximum allowable working pressure of cylindrical shells shall be the greater thickness or lesser pressure as given by (1) or (2) below.

(1) *Circumferential Stress (Longitudinal Joints).* When the thickness does not exceed one-half of the inside radius, or P does not exceed $0.385SE$, the following formulas shall apply:

$$t = \frac{PR}{SE - 0.6P} \quad \text{or} \quad P = \frac{SEt}{R + 0.6t} \quad (1)$$

(2) *Longitudinal Stress (Circumferential Joints).*¹⁶ When the thickness does not exceed one-half of the inside radius, or P does not exceed $1.25SE$, the following formulas shall apply:

$$t = \frac{PR}{2SE + 0.4P} \quad \text{or} \quad P = \frac{2SEt}{R - 0.4t} \quad (2)$$

(d) *Spherical Shells.* When the thickness of the shell of a wholly spherical vessel does not exceed $0.356R$, or P does not exceed $0.665SE$, the following formulas shall apply:

$$t = \frac{PR}{2SE - 0.2P} \quad \text{or} \quad P = \frac{2SEt}{R + 0.2t} \quad (3)$$

(e) When necessary, vessels shall be provided with stiffeners or other additional means of support to prevent overstress or large distortions under the external loadings listed in UG-22 other than pressure and temperature.

(f) A stayed jacket shell that extends completely around a cylindrical or spherical vessel shall also meet the requirements of UG-47(c).

(g) Any reduction in thickness within a shell course or spherical shell shall be in accordance with UW-9.

UG-28 THICKNESS OF SHELLS AND TUBES UNDER EXTERNAL PRESSURE

(a) Rules for the design of shells and tubes under external pressure given in this Division are limited to cylindrical shells, with or without stiffening rings, tubes, and spherical shells. Three typical forms of cylindrical shells are shown in Fig. UG-28. Charts used in determining minimum required thicknesses of these components are given in Subpart 3 of Section II, Part D.

(b) The symbols defined below are used in the procedures of this paragraph:

A = factor determined from Fig. G in Subpart 3 of Section II, Part D and used to enter the applicable

¹⁶ These formulas will govern only when the circumferential joint efficiency is less than one-half the longitudinal joint efficiency, or when the effect of supplementary loadings (UG-22) causing longitudinal bending or tension in conjunction with internal pressure is being investigated. An example illustrating this investigation is given in L-2.1 and L-2.2.

FIG. UG-28 DIAGRAMMATIC REPRESENTATION OF VARIABLES FOR DESIGN OF CYLINDRICAL VESSELS SUBJECTED TO EXTERNAL PRESSURE

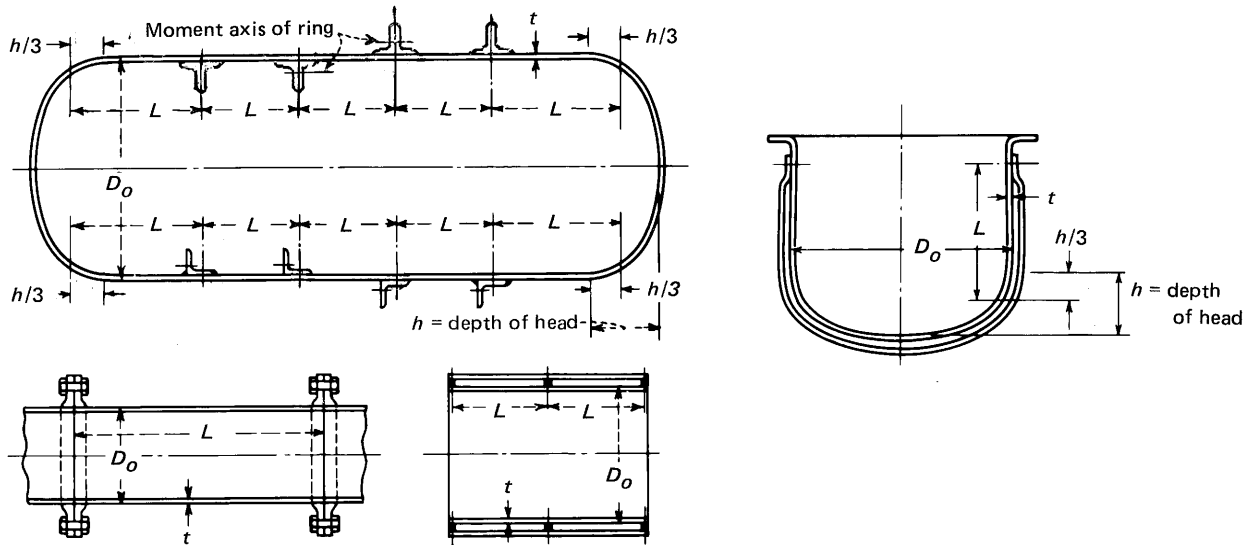

material chart in Subpart 3 of Section II, Part D. For the case of cylinders having D_o/t values less than 10, see UG-28(c)(2).

B = factor determined from the applicable material chart or table in Subpart 3 of Section II, Part D for maximum design metal temperature [see UG-20(c)]

D_o = outside diameter of cylindrical shell course or tube

E = modulus of elasticity of material at design temperature. For external pressure design in accordance with this Section, the modulus of elasticity to be used shall be taken from the applicable materials chart in Subpart 3 of Section II, Part D. (Interpolation may be made between lines for intermediate temperatures.)

L = total length, in. (mm), of a tube between tube-sheets, or design length of a vessel section between lines of support (see Fig. UG-28.1). A line of support is:

(1) a circumferential line on a head (excluding conical heads) at one-third the depth of the head from the head tangent line as shown on Fig. UG-28;

(2) a stiffening ring that meets the requirements of UG-29;

(3) a jacket closure of a jacketed vessel that meets the requirements of 9-5;

(4) a cone-to-cylinder junction or a knuckle-to-cylinder junction of a toriconical head or section that satisfies the moment of inertia requirement of 1-8.

P = external design pressure [see Note in UG-28(f)]

P_a = calculated value of maximum allowable external working pressure for the assumed value of t , [see Note in (f) below]

R_o = outside radius of spherical shell

t = minimum required thickness of cylindrical shell or tube, or spherical shell, in. (mm)

t_s = nominal thickness of cylindrical shell or tube, in. (mm)

(c) *Cylindrical Shells and Tubes.* The required minimum thickness of a cylindrical shell or tube under external pressure, either seamless or with longitudinal butt joints, shall be determined by the following procedure:

(1) Cylinders having D_o/t values ≥ 10 :

Step 1. Assume a value for t and determine the ratios L/D_o and D_o/t .

Step 2. Enter Fig. G in Subpart 3 of Section II, Part D at the value of L/D_o determined in Step 1. For values of L/D_o greater than 50, enter the chart at a value of $L/D_o = 50$. For values of L/D_o less than 0.05, enter the chart at a value of $L/D_o = 0.05$.

Step 3. Move horizontally to the line for the value of D_o/t determined in Step 1. Interpolation may be made for intermediate values of D_o/t . From this point of intersection move vertically downward to determine the value of factor A .

Step 4. Using the value of A calculated in Step 3, enter the applicable material chart in Subpart 3 of Section II, Part D for the material under consideration. Move vertically to an intersection with the material/temperature line for the design temperature (see UG-20). Interpolation may be made between lines for intermediate temperatures. If tabular values in Subpart 3 of Section II, Part D are used, linear

FIG. UG-28.1 DIAGRAMMATIC REPRESENTATION OF LINES OF SUPPORT FOR DESIGN OF CYLINDRICAL VESSELS SUBJECTED TO EXTERNAL PRESSURE

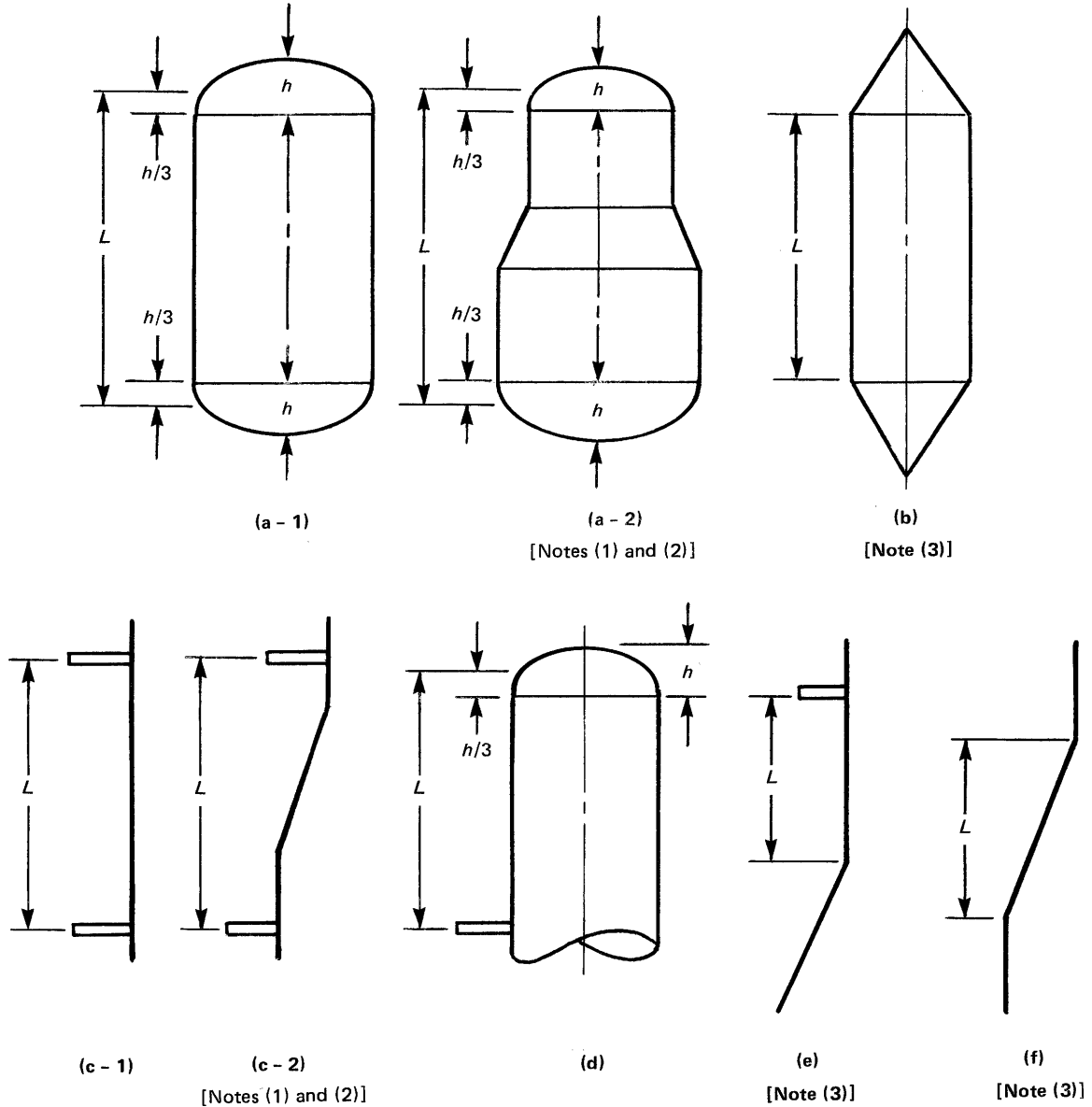

NOTES:

- (1) When the cone-to-cylinder or the knuckle-to-cylinder junction is not a line of support, the nominal thickness of the cone, knuckle, or toriconical section shall not be less than the minimum required thickness of the adjacent cylindrical shell.
- (2) Calculations shall be made using the diameter and corresponding thickness of each cylindrical section with dimension L as shown. Thicknesses of the transition sections are based on Note (1).
- (3) When the cone-to-cylinder or the knuckle-to-cylinder junction is a line of support, the moment of inertia shall be provided in accordance with 1-8.

interpolation or any other rational interpolation method may be used to determine a B value that lies between two adjacent tabular values for a specific temperature. Such interpolation may also be used to determine a B value at an intermediate temperature that lies between two sets of tabular values, after first determining B values for each set of tabular values.

In cases where the value of A falls to the right of the end of the material/temperature line, assume an intersection with the horizontal projection of the upper end of the material/temperature line. If tabular values are used, the last (maximum) tabulated value shall be used. For values of A falling to the left of the material/temperature line, see Step 7.

Step 5. From the intersection obtained in Step 4, move horizontally to the right and read the value of factor B .

Step 6. Using this value of B , calculate the value of the maximum allowable external working pressure P_a using the following formula:

$$P_a = \frac{4B}{3(D_o/t)}$$

Step 7. For values of A falling to the left of the applicable material/temperature line, the value of P_a can be calculated using the following formula:

$$P_a = \frac{2AE}{3(D_o/t)}$$

If tabular values are used, determine B as in Step 4 and apply it to the equation in Step 6.

Step 8. Compare the calculated value of P_a obtained in Steps 6 or 7 with P . If P_a is smaller than P , select a larger value for t and repeat the design procedure until a value of P_a is obtained that is equal to or greater than P . An example illustrating the use of this procedure is given in L-3(a).

(2) Cylinders having D_o/t values <10 :

Step 1. Using the same procedure as given in UG-28(c)(1), obtain the value of B . For values of D_o/t less than 4, the value of factor A can be calculated using the following formula:

$$A = \frac{1.1}{(D_o/t)^2}$$

For values of A greater than 0.10, use a value of 0.10.

Step 2. Using the value of B obtained in Step 1, calculate a value P_{a1} using the following formula:

$$P_{a1} = \left[\frac{2.167}{(D_o/t)} - 0.0833 \right] B$$

Step 3. Calculate a value P_{a2} using the following formula:

$$P_{a2} = \frac{2S}{D_o/t} \left[1 - \frac{1}{D_o/t} \right]$$

where S is the lesser of two times the maximum allowable stress value in tension at design metal temperature, from the applicable table referenced in UG-23, or 0.9 times the yield strength of the material at design temperature. Values of yield strength are obtained from the applicable external pressure chart as follows:

(a) For a given temperature curve, determine the B value that corresponds to the right hand side termination point of the curve.

(b) The yield strength is twice the B value obtained in (a) above.

Step 4. The smaller of the values of P_{a1} calculated in Step 2, or P_{a2} calculated in Step 3 shall be used for the maximum allowable external working pressure P_a . Compare P_a with P . If P_a is smaller than P , select a larger value for t and repeat the design procedure until a value for P_a is obtained that is equal to or greater than P .

(d) *Spherical Shells.* The minimum required thickness of a spherical shell under external pressure, either seamless or of built-up construction with butt joints, shall be determined by the following procedure:

Step 1. Assume a value for t and calculate the value of factor A using the following formula:

$$A = \frac{0.125}{(R_o/t)}$$

Step 2. Using the value of A calculated in Step 1, enter the applicable material chart in Subpart 3 of Section II, Part D for the material under consideration. Move vertically to an intersection with the material/temperature line for the design temperature (see UG-20). Interpolation may be made between lines for intermediate temperatures. If tabular values in Subpart 3 of Section II, Part D are used, linear interpolation or any other rational interpolation method may be used to determine a B value that lies between two adjacent tabular values for a specific temperature. Such interpolation may also be used to determine a B value at an intermediate temperature that lies between two sets of tabular values, after first determining B values for each set of tabular values.

In cases where the value at A falls to the right of the end of the material/temperature line, assume an intersection with the horizontal projection of the upper end of the material/temperature line. If tabular values are used, the last (maximum) tabulated value shall be used. For values at A falling to the left of the material/temperature line, see Step 5.

Step 3. From the intersection obtained in Step 2, move horizontally to the right and read the value of factor B .

Step 4. Using the value of B obtained in Step 3, calculate the value of the maximum allowable external working pressure P_a using the following formula:

$$P_a = \frac{B}{(R_o/t)}$$